

Wide Band VCO

5.0 to 8.4 GHz

Electrical specification

Type number	VO4280C/00		
Package	SMA house		
Parameter	Min.	Max.	Unit
Frequency range*	5.0	8.4	GHz
Output power, over all*	14	19	dBm
Power vs. frequency*		4	dB
Power vs. temperature*		2	dB
Temperature drift *		3	MHz/°C
2:nd harmonic		- 25	dBc
Spurious		- 60	dBc
FM noise (SSB) 100 kHz 1MHz		-85 -105	dBc/Hz dBc/Hz
Tuning voltage*	0	+20	V
Tuning sensitivity*	100	600	MHz/V
Non-linearity		±10	%
Pulling, VSWR 1.5:1		±2	MHz
Pushing 11.5-12.5 V		1	MHz/V
Slew rate	20		GHz/μs
Modulation bandwidth	10		MHz
PTD 1μs to 1s after freq. jump		± 25	MHz

$T_a = 25^\circ\text{C}$, unless otherwise stated.



Dimensions

44.0x31.0x10.0mm

Note:

*100% tested and guaranteed values. Other data are indicative

Interface/environmental specification

Parameter	Min.	Max.	Unit
Bias voltage	11	16	V
Bias current		200	mA
Tuning voltage (damage level)		21	V
Operating temperature	0	+60	°C
Storage temperature	-50	+100	°C

Typical Pout vs. frequency

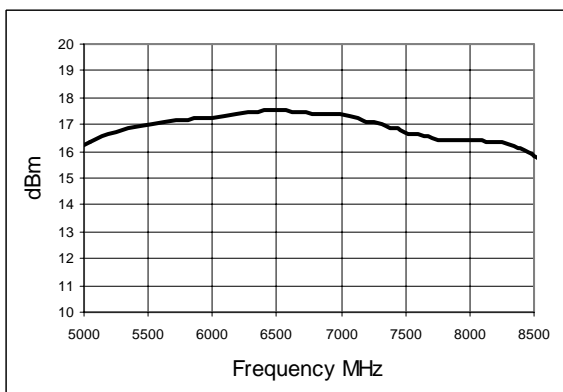

Typical frequency vs. Vtune

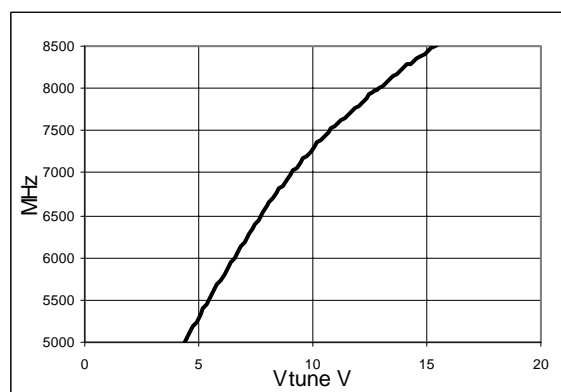

Data subject to change without notice. Rev.A 2006-09-30

Wide Band VCO

5.0 to 8.4 GHz

Simplified block diagram

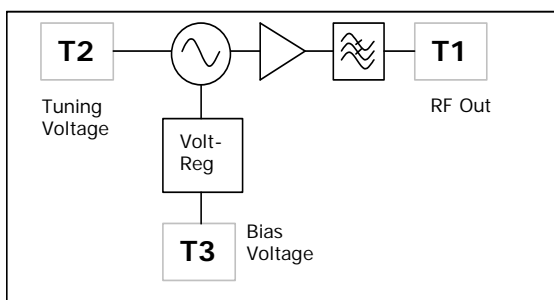

Tuning input interface

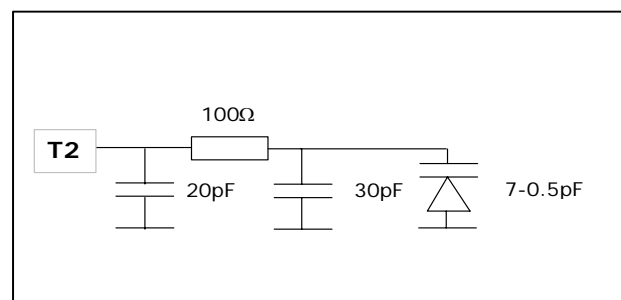

Data subject to change without notice. Rev.A 2006-08-22