

FMCW Transceiver

RS3400K/00

Features:

- Complete K-band FMCW Radar Front End
- Intrinsic Safe Design
- Synthesized Frequency Source
- Wideband Sweep
- Low Power Consumption

Description:

The RS3400K/00 is a synthesized, K-band, FMCW radar front end. It is designed according to previously proven concepts for intrinsic safety giving a reliable unit with low power consumption. It utilizes only packaged low-cost components, which makes low unit prices and high volumes possible.

The frequency is digitally controlled via a standard, 3-wire serial interface, which programs a modern high performance synthesizer circuit.

A complete kit for controlling the unit through RS-232 or USB from a PC for easy evaluation is available.

Performance Specification:

Guaranteed values. Tested or implicated by design. All units are tested at operating temperature range limits and at room temperature.

Parameter	Min.	Typ.	Max.	Unit
RF: (Probing signal)				
Minimum output frequency			24000	MHz
Maximum output frequency	25500			MHz
Frequency stability ¹			35	ppm
Bandwidth stability			35	ppm
Frequency setting resolution	2			kHz
Frequency settling time ²		40	250	μs
Output port return loss	12			dB
IF: (Sensor output)				
Full reflection response amplitude ³	-12	-6	0	dBV _{pp}
Reflection response amplitude variation		3	3.6	dB
Sensor performance (uncalibrated):				
Range measurement variation ⁴		100	300	ppm

¹ Over operating temperature range, input voltage variation, aging, shock, and vibration.

² Defined as time elapsed for a signal to settle within 0.1MHz of a 1 MHz frequency step. Settling time is strongly dependent on digital parameters settings within the FMCW module.

³ Defined as IF output signal when the complete RF (probing signal) is returned from a target.

⁴ Defined as variation in range measurements over temperature for two targets 5m < separation < 6m apart.

Data subject to change without notice.
SPLT6118_RS3400K00_B.doc

FMCW Transceiver

RS3400K/00

Typical values, not tested.

Parameter	Min.	Typ.	Max.	Unit
RF output power	5	10	15	dBm
RF output power variation (over frequency)			5	dB
RF output power variation (over temperature)			5	dB
Harmonics related to carrier			-20	dBc
Spurious (synthesizer related) ⁵			-26	dBc
Spurious (not synthesizer related)			-60	dBc
SSB phase noise @ 100 kHz from carrier			-67	dBc/Hz
RF to IF conversion efficiency ⁶		-20		dB
Sensor dynamic range ⁷		-80		dBc
Power consumption		900		mW
Total internal capacitance			100	nF

Environmental Specification:

Parameter	Min.	Max.	Unit
Operational temperature range ⁸	-10	+70	°C
Storage temperature range	-50	+100	°C
Vibration		TBD	
Shock ⁹		100g 6ms	

⁵ Average over whole frequency band.

⁶ The IF signal power is measured as a single ended voltage from the IF port. The signal is internally terminated in a 150 Ω resistor.

⁷ Defined as signal level below full reflection response adjacent to detected peak in fourier transformed IF signal.

⁸ Other temperature ranges available upon request.

⁹ According to MIL-STD-202G method 213B.

FMCW Transceiver

RS3400K/00

Outline Drawing [mm]:

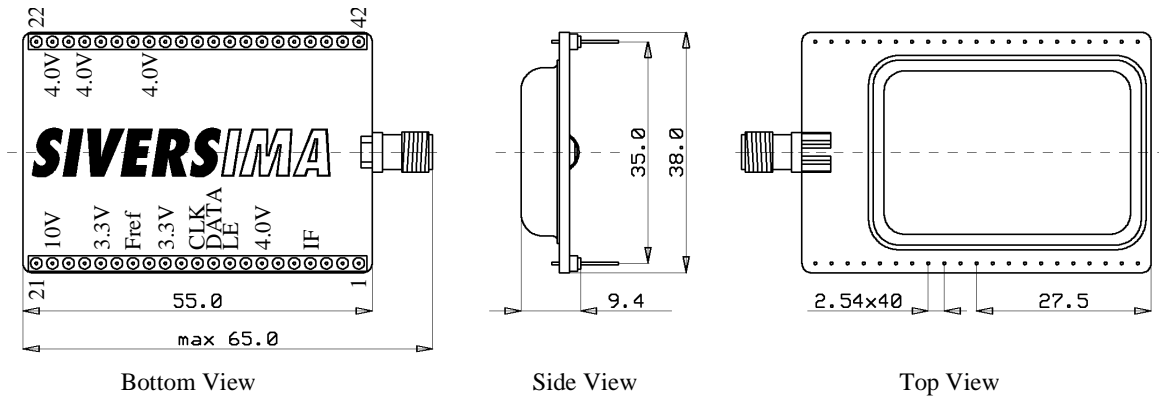

Interfaces:

SMA-female

Samtec interconnect strips, BBL-121-G-E. Mating connector: SL-series.

Pin ¹⁰	Description	Specification
23	Power Supply	+4.0 V (max 4.3V), app. 25 mA
25	Power Supply	+4.0 V (max 4.3V), app. 25 mA
29	Power Supply	+4.0 V (max 4.3V), app. 25 mA
20	Power Supply for synthesizer active loop filter	+10.0 V (max 18V), approx. 1 mA
17	Power Supply	+3.3V (max 3.6 V), app. 35 mA
13	Power Supply	+3.3 V (max 3.6 V), app. 10 mA
11	Clock signal for Synthesizer	5.0 V ≥ Logic Level High ≥ 2.7 V
10	Data signal for Synthesizer	0.7 V ≥ Logic Level Low ≥ 0 V
9	Latch/Enable signal for Synthesizer	Load resistance: 10kΩ
7	Power Supply	+4.0 V (max 4.3V), app. 80 mA
4	IF (Baseband) Output	DC-coupled, output impedance 150Ω.

¹⁰ See bottom view above