

## Ultra Wide Band VCO

*"A small subsystem, not just a Component"*



Drop in

### Features

- Low phase noise
- Excellent pushing and pulling
- Low spurious
- Hermetic thin film/MMIC technology
- Individual recorded data available for each unit
- Very small in size



In SMA house

### General description

These new ultra wide band voltage controlled oscillators features an improved integrated voltage regulator making them even more resistant to external power variations. By using the latest MMIC technology it has been possible to design a much smaller unit and also enhance uniform performance in serial production.

The oscillator series from S- to P-band covers from 3 to 20 GHz in only four units! The oscillators are all fundamental frequency versions and all have built-in regulators, buffer amplifiers and output filters. All oscillators are available as drop in or in a SMA house for EMI protection.

The temperature range can easily be extended to cover -40°C to +85°C. However, the standard units are tested and specified to cover a temperature range of 0°C to 60°C.

### Typical applications are:

- Microwave instruments
- Sensors
- Radar equipment
- Microwave communication equipment
- ECM (Electronic counter measure)

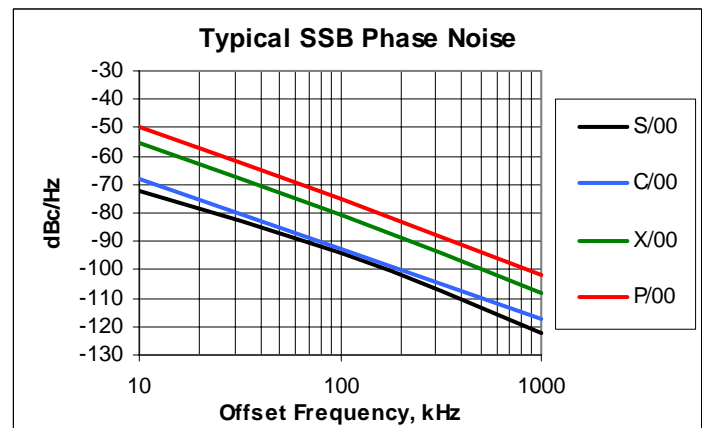

September 30, 2006

## Ultra Wide Band VCO

### List of Ultra Wide Band VCO models.

Model	Model	Frequency	Output
Drop in	SMA house		
VO3280S/00	VO4280S/00	3.0 – 5.0 GHz	14-19 dBm
VO3280C/00	VO4280C/00	5.0 – 8.4 GHz	14-19 dBm
VO3280X/00	VO4280X/00	8.4 – 13.5 GHz	14-19 dBm
VO3280P/00	VO4280P/00	13.5 – 20.0 GHz	14-19 dBm

Detailed data specifications are available at our web site, [www.siversima.com](http://www.siversima.com)

### Customized versions

The VCO:s above are examples of our wide band VCO family. For special requirements, tailored to your needs and application, please contact our sales department.

September 30, 2006

## Ultra Wide Band VCO

*"A small subsystem, not just a Component"*

Our Ultra Wide Band solution enable simplified design resulting in reduced cost and reliable systems.

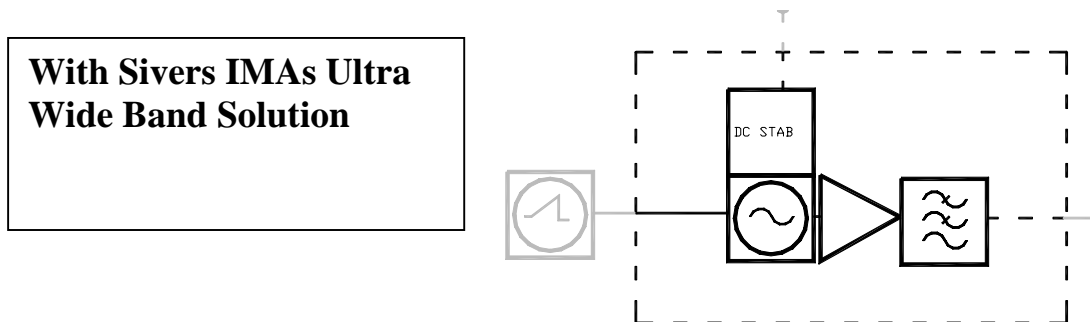
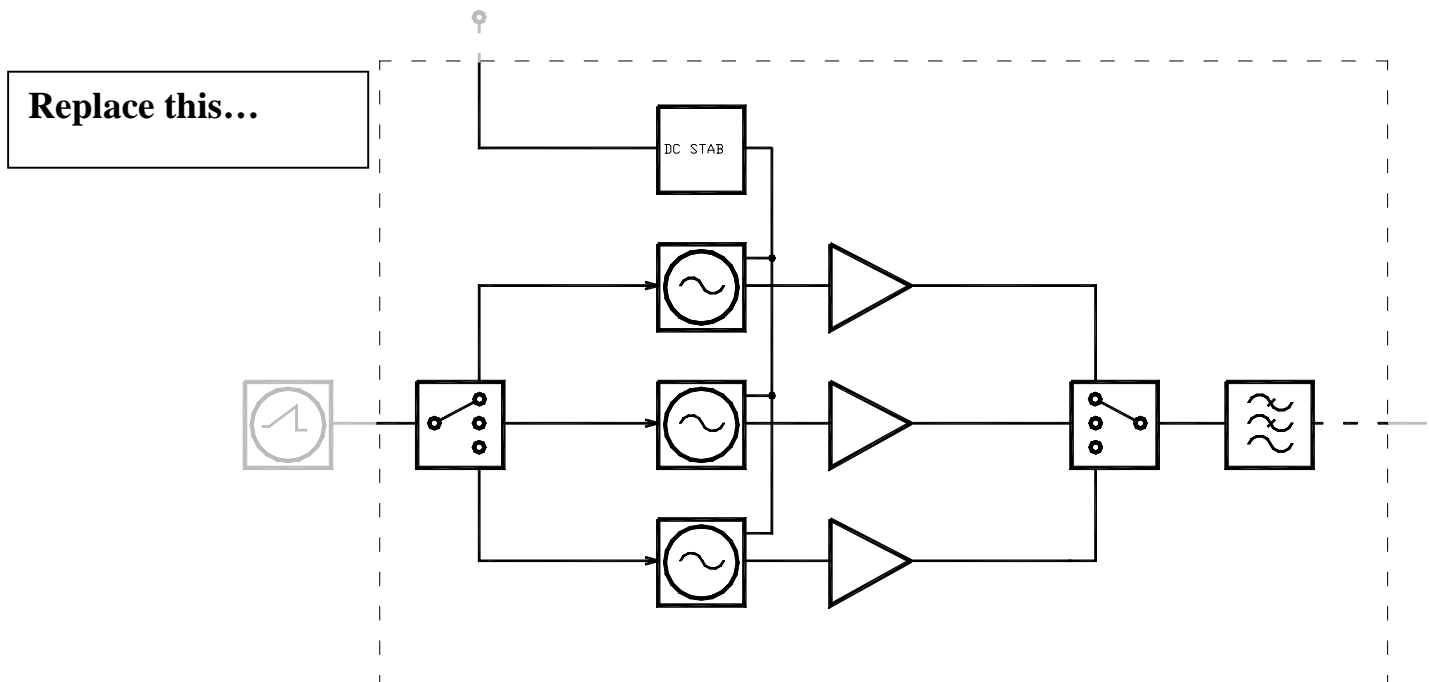

September 30, 2006