

Wide Band VCO

VO3252P/02

Electrical specification

Parameter	Min.	Typ.	Max.	Unit
Frequency range*	13.5		20.0	GHz
Output power, over all*	21***		28	dBm
Power vs. frequency*		2	4	dB
Power vs. temperature*		1.5	2	dB
Temperature drift *		2	3	MHz/°C
2:nd harmonic		-30	- 25	dBc
Spurious			- 60	dBc
FM noise* (SSB) 100 kHz 1MHz		-72 -102	-65 -95	dBc/Hz dBc/Hz
Tuning voltage*	0		+20	V
Tuning sensitivity*	100		600	MHz/V
Non-linearity			±10	%
Pulling, VSWR 1.5:1 ****		±1	±2	MHz
Pushing		0.2	1	MHz/V
Slew rate	20	80		GHz/μs
Modulation bandwidth	10	13		MHz
PTD**			±25	MHz

T_a = 25°C, unless otherwise stated.

Notes:
 * 100% tested and guaranteed values. Other data are indicative.
 ** from 1μs to 1s after frequency jump
 *** 20dBm vid >65°C

****No frequency jump for any mismatch |S11| ≤ 1

Interface/environmental specification

Parameter	Min	Max	Unit
Bias voltage	14.6	16	V
Bias current*		300	mA
Tuning voltage (damage level)		21	V
Operating temperature	0	+70	°C
Storage temperature	-50	+100	°C
Weight		7	g

Typical Pout vs. frequency

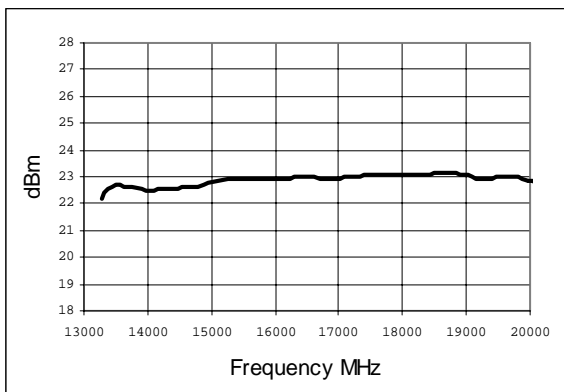

Typical frequency vs. Vtune

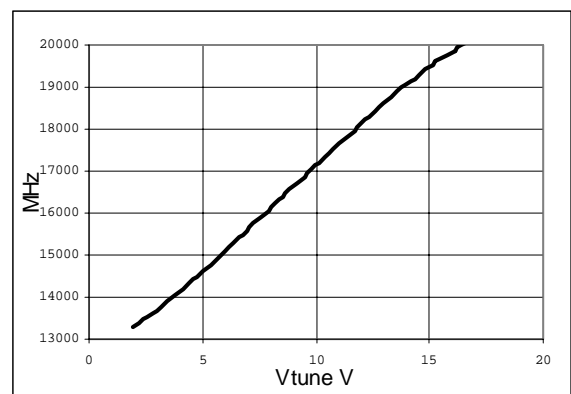

Note: Actual performance for each individual is stored in standard file format !

Wide Band VCO

VO3252P/02

Outline drawing

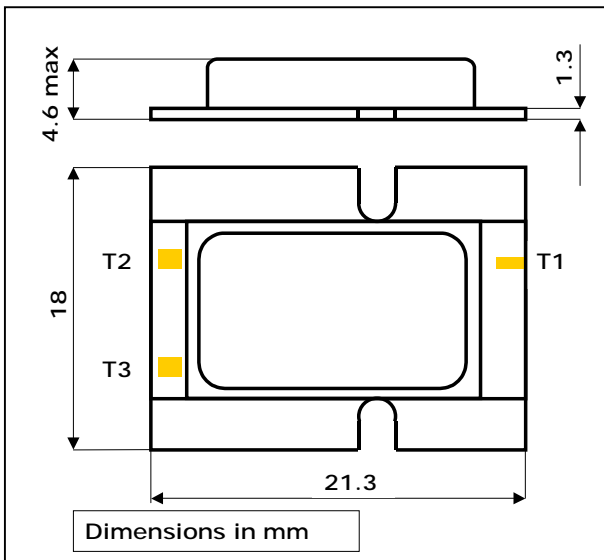

T1	RF Out (50 Ω)	Bond Pad	0.25 x 0.50 mm
T2	Tuning Voltage	Bond Pad	0.80 x 0.80 mm
T3	Bias Voltage	Bond Pad	0.80 x 0.80 mm

Simplified block diagram

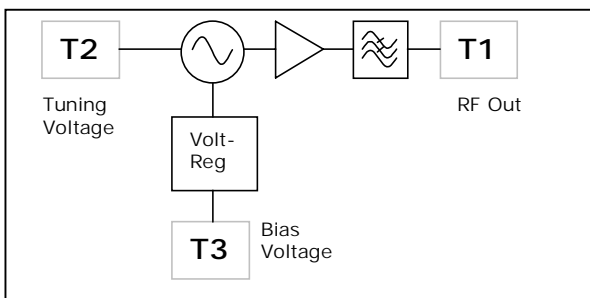

Tuning input interface

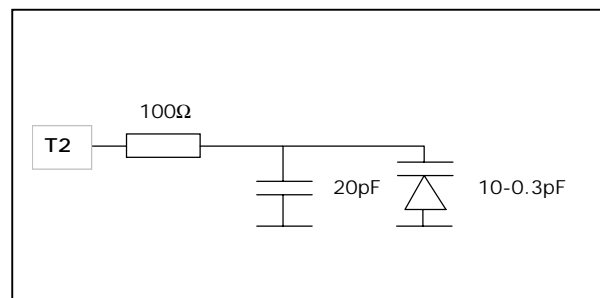

Data subject to change without notice.
SPLT6018_C_VO3252P02.doc